

SWIM BIKE RUN

Europe Triathlon Cup City of Derry
Workbook

Key Stage 2

Year 3,4, 5 and 6 (ages 7-11)

Triathlon
Ireland

1. ABOUT THIS WORKBOOK

Triathlon Ireland is the national governing body for multisport across the island of Ireland. As part of our Tri Heroes Schools Programme this workbook is all about helping children to discover triathlon - the sport that combines swimming, cycling and running.

This special edition workbook has been created for the Europe Triathlon Cup City of Derry taking place on Saturday 5th September. Triathletes from across the world will Swim 750m in the River Foyle, Cycle 20km around the City and Run 5km across the Peace Bridge and finish in Ebrington Square.

IN THIS WORKBOOK: :

- 1 What is triathlon?
- 2 What do I need for a triathlon?
- 3 Triathlon matching task
- 4 Triathlon crossword
- 5 Join the dots
- 6 Design a medal
- 7 Design a tri suit
- 8 Design a poster
- 9 Triathlon Pathway and Development
- 10 Triathlon Glossary



THIS WORKBOOK BELONGS TO

Name:

Class:

Date:

2. TRIATHLON EQUIPMENT

Triathlon Equipment

Ryan and Aisling want to part in their first ever triathlon event. They are going to be swimming in open water, cycling and running in the local park. They will need to change gear as they transition from one sport to the next.

They ask their friends Charlie and Taylor, who have completed an event before, to show them all the things they will need. Can you help Ryan and Aisling? Colour the items and help them decide what items they need for each part of the race by drawing a line to the correct box.

Swim

Bike

Run

General

3. TRIATHLON MATCHING TASK

The word Triathlon comes from Tri meaning three and Athlon means contest. A contest across three sports!

While Triathlon is a single event, it involves three sports. These sports are called Disciplines they are: Swim, Bike and Run. And to move from one sport to another is called Transition. There are two transitions, T1 and T2. The first from swim to bike, the second from bike to run.

TASK: COLOUR IN, CUT OUT, LABEL AND PUT THE STAGES IN CORRECT ORDER OR DRAW A LINE MATCH THE PICTURE TO THE WORDS.

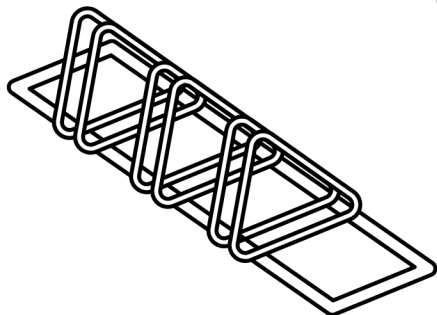
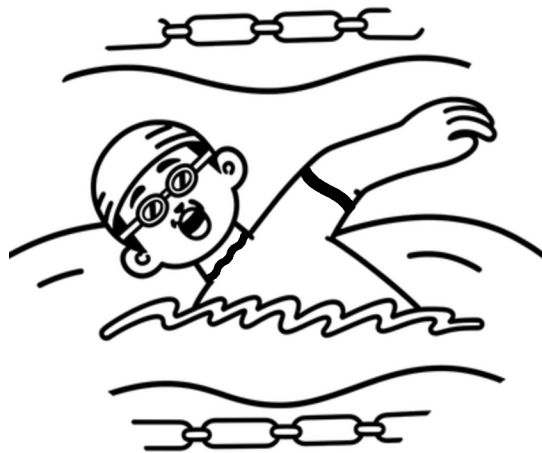

Swim

T1

Bike

T2

Run

Finish

4. TRIATHLON CROSSWORD



Follow the clues to the crossword and find the answers on the sheet at the bottom of the page.

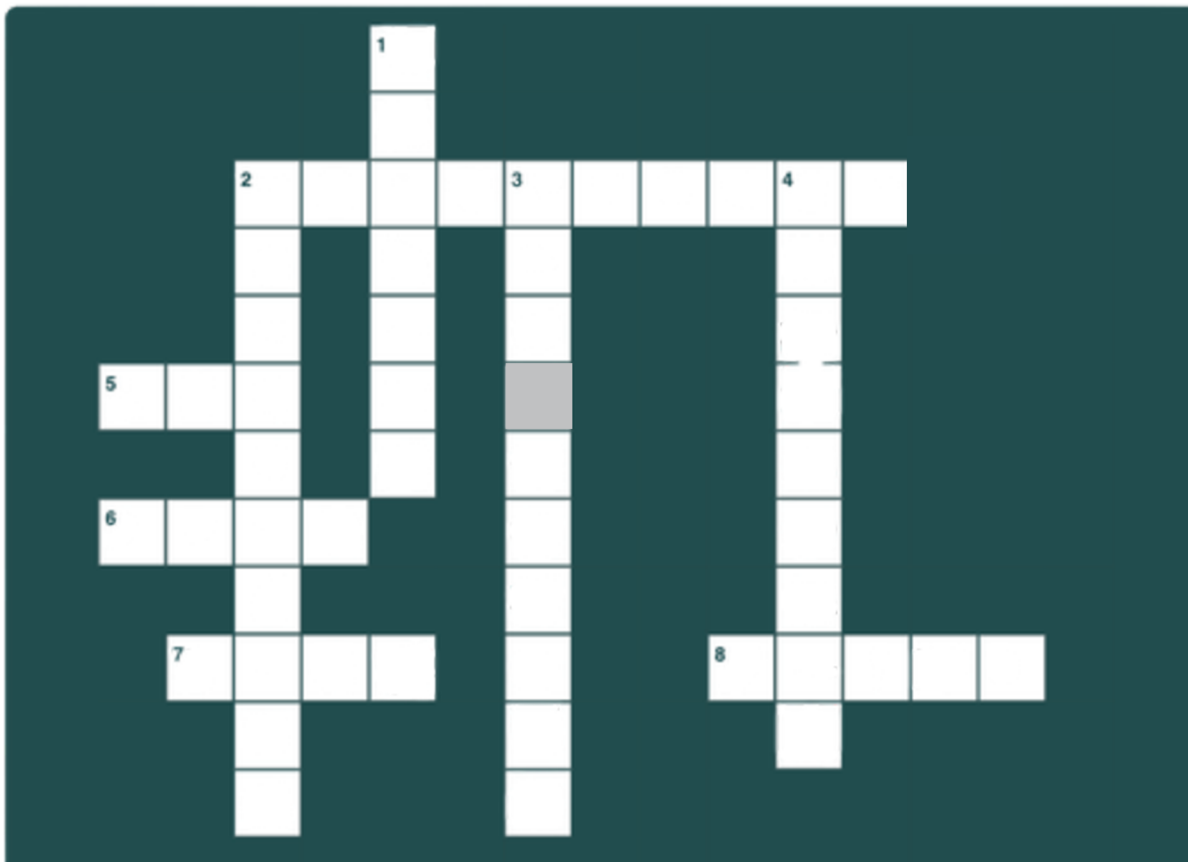

Hints

Across:

2. The name of a person who does triathlon
5. The last sport in a triathlon
6. The first sport in a triathlon
7. The equipment a triathlete uses to cycle
8. The river in the Europe Triathlon Cup City of Derry race

Down:

1. The name of the suit triathletes wear
2. The place where athletes go to change from swim to bike, and bike to run
3. The name of the Triathlon Ireland Schools Programme
4. An event that involves swim, bike and run

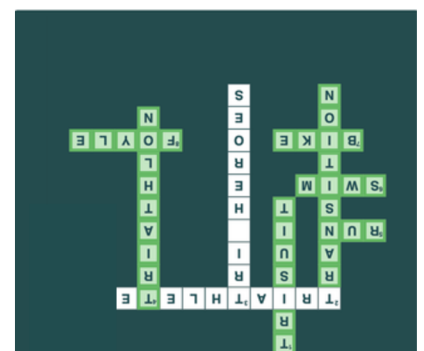

5. JOIN THE DOTS

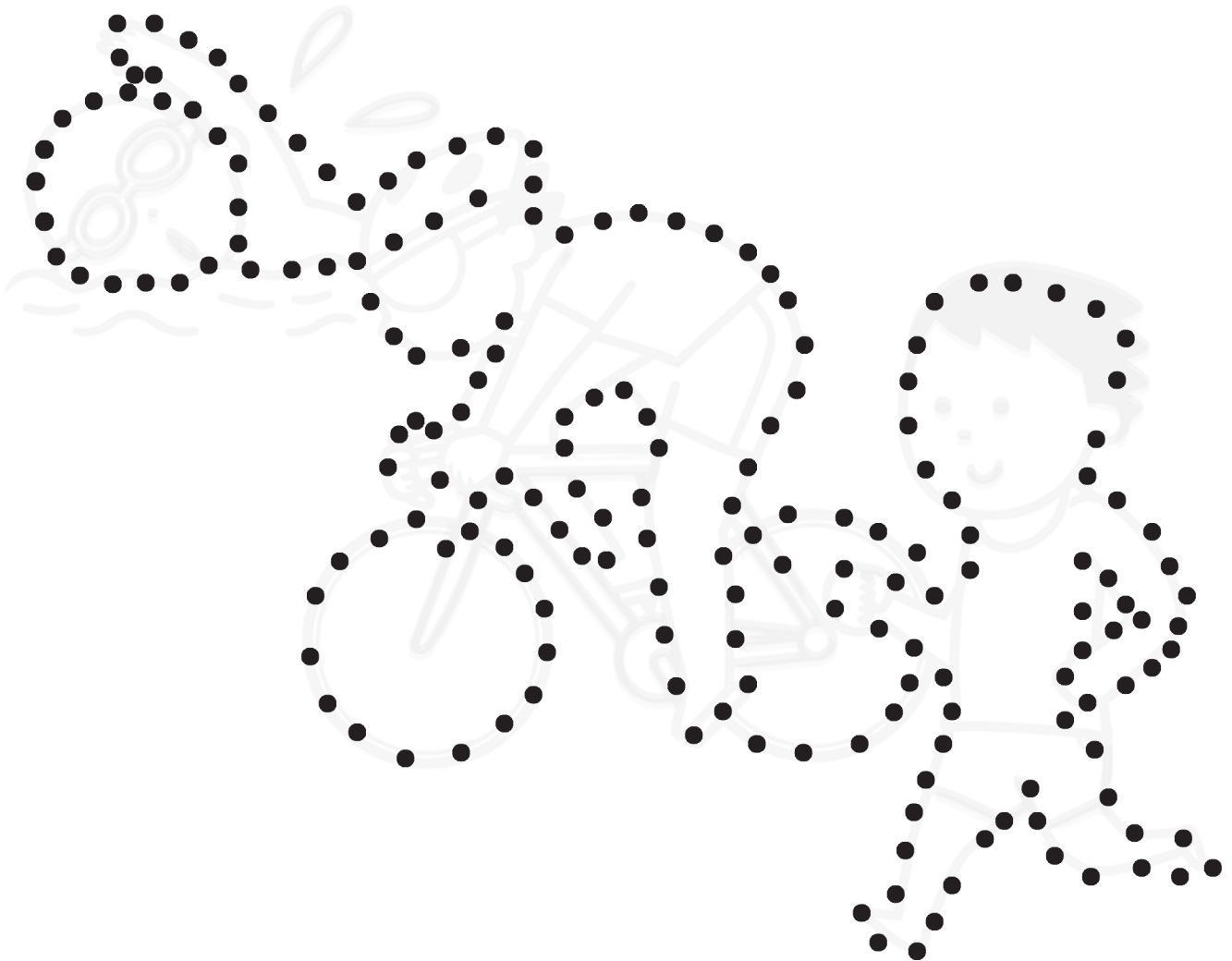

TASK: JOIN THE DOTS

Join the dots and colour in the picture afterwards

6. DESIGN A MEDAL

Design a medal for the Europe Triathlon Cup City of Derry



DESIGN BY :

Name:

Age:

School:

7. DESIGN A TRI SUIT



When taking part in a triathlon, athletes need to have sports gear that allows them to swim, cycle and run without changing clothing.

The suit they wear is called a Tri Suit. It is made of swimsuit material with padding for cycling and is also comfortable for the run.

TASK: DESIGN A TRI SUIT. THINK ABOUT COLOUR, PATTERN, LOGO AND NAME.

EXAMPLE:

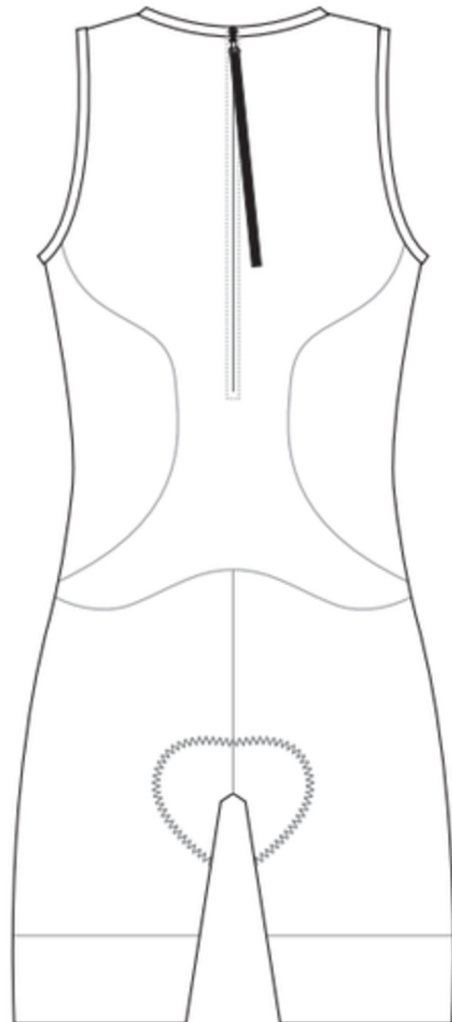
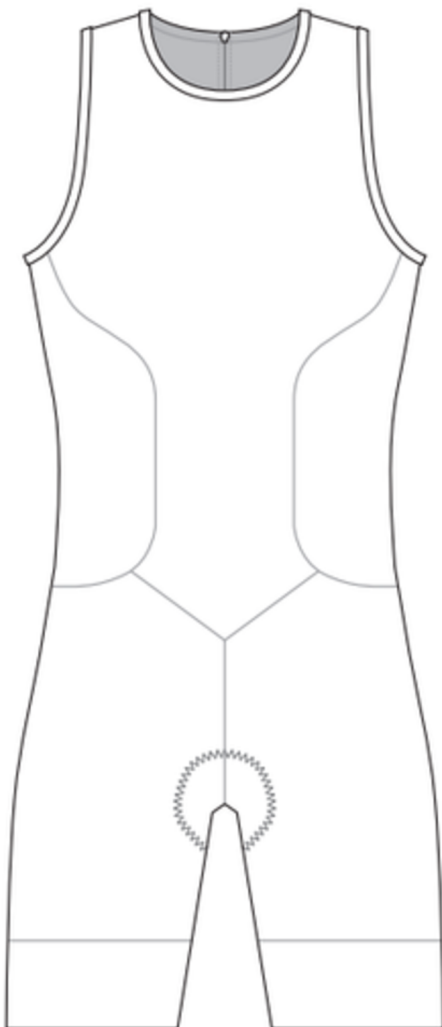
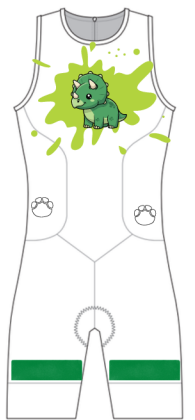

8. DESIGN A POSTER

Design a poster to advertise the City of Derry Triathlon Fun Run or Triathlon!

On another piece of paper design a poster for the Fun Run or City of Derry Triathlon. Include information such as the date, time, location and what people can expect to experience (do, see, feel, hear) at the race!

SOME EXAMPLES



ABOUT THE EVENTS

Friday 4th September

Fun Run and Try a Tri 6pm - 7.30pm Ebrington Square. Register via EventBrite.

Saturday 5th September

Adult Triathlon Swim 750m River Foyle, Cycle 20km around the city, Run 5km along Queen's Quay and across Peace Bridge. Finish in Ebrington Square. Register at TriathlonIreland.com

POSTER COMPETITION



DESIGN BY :

Name:

Age:

School:

9. TRIATHLON PATHWAY AND DEVELOPMENT

This shows how triathletes can progress from Juniors to International Competition - and even to the Olympics and Paralympics!

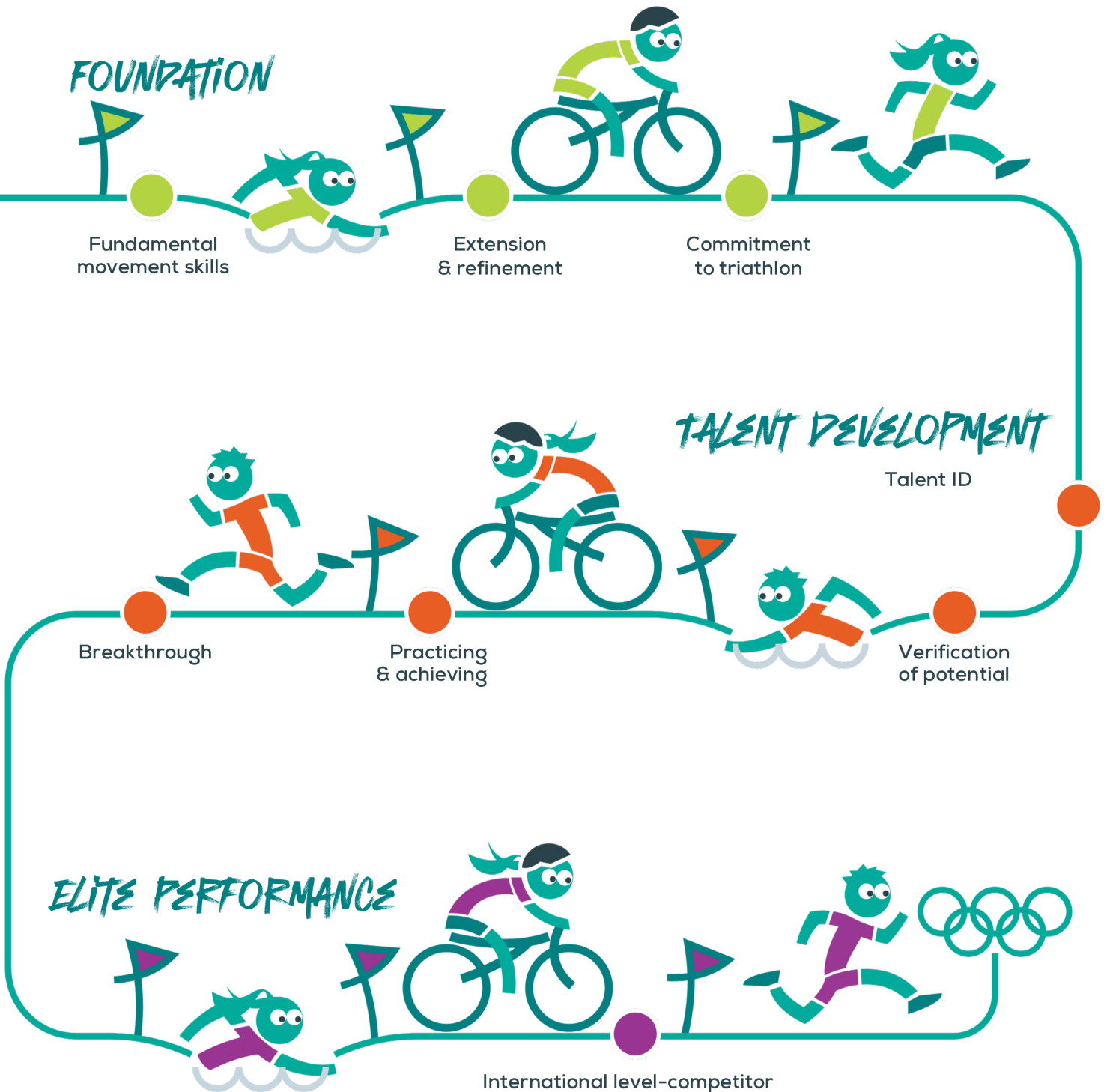

10. TRIATHLON GLOSSARY

This glossary explains some of the special words used in triathlon so you can understand the sport and talk like a real triathlete!

Age Group: The age you are on December, 31st of the race year. That's the age group you'll be racing in.

Aquabike: A race where you swim and bike.

Aquathlon: A race where you swim and run.

Bib: The race number you wear so people know who you are in the race.

Course: The path or route you follow for swimming, cycling and running.

Chip: A small timer you wear on your ankle that tracks how fast you go and where you finish in the race.

DNF: This means an athlete started a race but did not finish.

DNS: This means an athlete did not start the race.

Duathlon: A race where you run, bike, run.

Finish line: The end of the race where you run and get your medal.

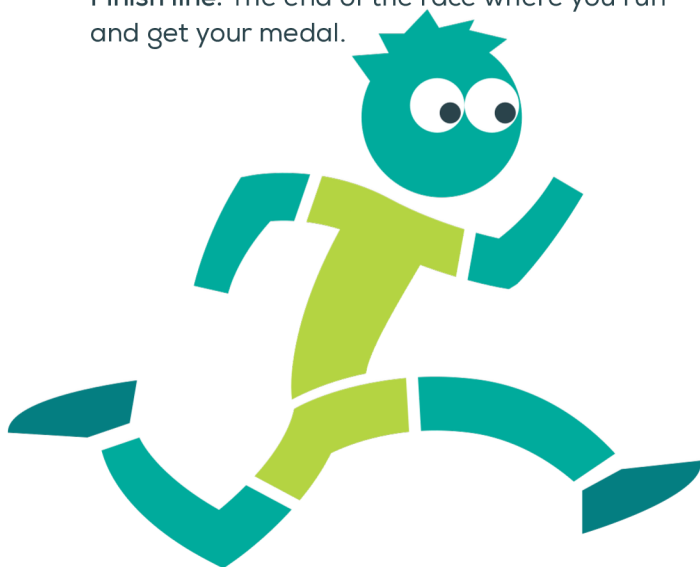

Junior Club: A Triathlon Club where young athletes train.

Pace: How fast or slow you go in each part of the race.

PB (Personal Best): Your fastest time in a race.

T1 /Transition 1: When you switch from swimming to biking. You take off your swim gear and put on your bike gear.

T2 / Transition 2: When you switch from biking to running. You take off your bike gear and get ready to run.

Transition Area: A special space where you keep your bike, shoes and gear during the race. You stop here to change between the swim, bike and run.

Triathlon: A race in three parts - swim, bike and run.

Tri Heroes: Triathlon Ireland's Schools Programme

Tri-suit: A special suit made from swimming costume material that can be worn throughout the race.

Spectators: The family, friends of club mates who cheer for you along the course.

Volunteer: A race official or marshall who helps ensure the race is safe and rules are followed.

Wetsuit: Swimmers wear a rubbery suit when they are in cold water to keep their bodies warm and to help float better.

Youth Series: Junior Races that take place across the season.

WELL DONE!

You did it!

You've raced your way through this workbook like a true triathlete! Now it's time for your next adventure...

Join the Triathlon Ireland Team on Friday 4th September at 6pm in Ebrington Square to join in the Triathlon Taster and Fun Run. Bring your parent or guardian and find out all about Tri Heroes - Triathlon Ireland's Schools Programme and explore Junior Triathlon Club membership with North West Triathlon Club.

We look forward to seeing you there!



Ask your parent or guardian to scan the QR code to find out more about the City of Derry Triathlon Taster Session and Fun Run!





Triathlon Ireland